

LUBRICATION ORDER

LI-035238-10/1B

L05-2805-258-12

20 September 1989

(Supersedes LO 5-2805-258-12, 23 October 1978)

ENGINE, GASOLINE: 10 HP; MILITARY STANDARD MODELS

(MODEL 2A042-2, MODEL 2A042-3, AND MODEL 2A042-4)

Reference: TM 5-2805-258-14 and C9100-1L

Intervals and related task-hour times are based on normal hours of operation. The task-hour time specified is the time you need to do all the services prescribed for a particular interval. Change the interval if your lubricants are contaminated or if you are operating the equipment under adverse operating conditions, including longer-than-usual operating hours. You may extend the interval during periods of low activity, but you must take adequate preservation precautions.

*The time specified is the time required to perform all services at the particular interval.

Clean fittings before lubricating. Clean parts with

SOLVENT dry cleaning, or with OIL, fuel, diesel. Dry before lubricating. Drain crankcase when HOT. Fill and check level. The lowest level of maintenance authorized to lubricate a point is indicated by one of the following (C) Operator/crew; or (O) Organizational Maintenance.

You can help improve this publication. If you find any mistake or if you know of a way to improve the procedures, please let us know. Your letter or DA Form 2028 (Recommended Changes to Publications and Blank Forms) should be mailed directly to: Commander, U.S. Army Troop Support Command, ATTN: AMSTR-MCTS, 4300 Goodfellow Blvd. St. Louis, MO 63120-1798. A reply will be furnished to you.

*TOTAL TASK-HRS		*TOTAL TASK-HRS	
INTERVAL	TASK-HR	INTERVAL	TASK-HR
8	0.1		
50	0.5		

LUBRICANT • INTERVAL

INTERVAL • LUBRICANT

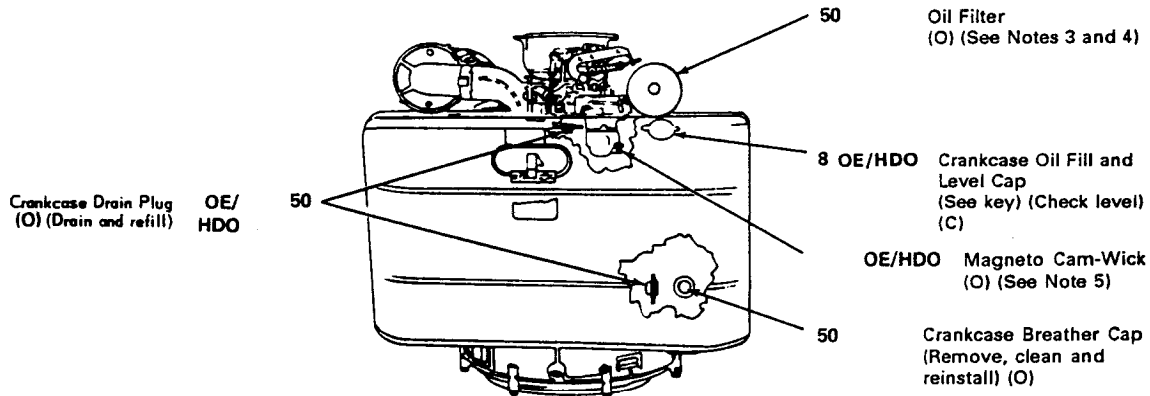

— KEY —

LUBRICANTS	REFILL CAPACITY (APP)	EXPECTED TEMPERATURES			INTERVALS
		Above +32°F Above 0°C	+40°F to -10°F + 5°C to -23°C	0°F to -65°F -18°C to -50°C	
OE/HDO LUBRICATING OIL, (MIL-L-2104C) Engine					Intervals given are in hours of normal operation.
Crankcase	2-1/2 qts (2.375L)	OE/HDO 30	OEA/APG-PD-1	OEA/APG-PD-1	
Oil Can Points					
OEA/APG-PD-1 OIL, Engine, Subzero					

NOTES:

1. FOR OPERATION OF EQUIPMENT IN PROTRACTED COLD TEMPERATURES BELOW -100°F (-23°C). Remove lubricants prescribed in the key for temperatures above -100°F (-23°C). Clean parts with SOLVENT, dry-cleaning. Relubricate with lubricants specified in the key for temperatures below -100°F (-23°C).

2. OIL CAN POINTS. Every 25 hours lubricate all exposed adjusting threads with OE/HDO.

3. OIL FILTER - ELEMENT TYPE. Every 50 hours remove filter element, clean housing, install new element, fill crankcase, operate engine for five minutes, check for leaks, check crankcase oil level, and bring to full mark.

4. OIL FILTER - SPIN ON TYPE. Every 50 hours remove oil filter, clean housing and install new oil filter, fill crankcase, operate engine for five minutes, check for leaks, check crankcase oil level, and bring to full mark.

5. Insure cam wick is lubricated with OE/HDO (sparingly) whenever ignition contact points are replaced or adjusted.

Copy of this Lubrication Order will remain with the equipment at all times; instructions contained herein are mandatory.

By Order of the Secretary of the Army:

CARL E. VUONO

*General, United States Army
Chief of Staff*

Official:

WILLIAM J. MEEHAN, II

*Brigadier General, United States Army
The Adjutant General*

DISTRIBUTION:

To be distributed in accordance with DA Form 12-25A, Operator and Unit, Maintenance requirements for Engine, Gasoline, 10 HP, Models 2A042-2/3